KIT PART NUMBER 1670082
INSTRUCTIONS FOR INSTALLING A
SECURITY LOCK KIT

CHECK THE PARTS RECEIVED IN THE KIT WITH THE PARTS LIST IN THESE INSTRUCTIONS. IF ANY PARTS ARE MISSING, CONTACT THE CRANE MERCHANDISING SYSTEM'S PARTS DEPARTMENT AT 1-800-621-7278.

Read these instructions carefully before installing the kit.
Keep these instructions for part numbers and for future reference

THIS KIT CONTAINS THE FOLLOWING :

PART NUMBER	DESCRIPTION	QUANTITY
1106656	CARRIAGE BOLT-#8-32X5/16 ZP	2
2221908	CARRIAGE BOLT-BASE PLATE	1
2802013	LEVER-LOCK-HI SECURITY	1
2802014	COVER-LEVER-LOCK-HI SECURITY	1
9900081	NUT #8-32 KEPS ZINC PLATE	2
9900152	NUT #10-24	1
1670083	KIT INSTRUCTIONS	1

- 1. Unlock door latch and remove the lock cylinder.**
(Refer to Figure 1 for Steps 1-9)
- 2. Remove the two standard screws holding the lock bar actuator assembly and remove the lock bar actuator assembly.**
- 3. Remove the two standard screws holding the door latch catch.**
- 4. Remove the door latch catch, latch shield, steel washer, and the lower lock latch.**
- 5. Remove the screw and the cup spacer located at the top of the handle assembly.**
- 6. Remove the handle assembly from the machine.**
- 7. Lift up on the lock lever from the lever lock base.**
- 8. Remove the lever lock pivot.**
- 9. Separate the base assembly from the handle assembly.**

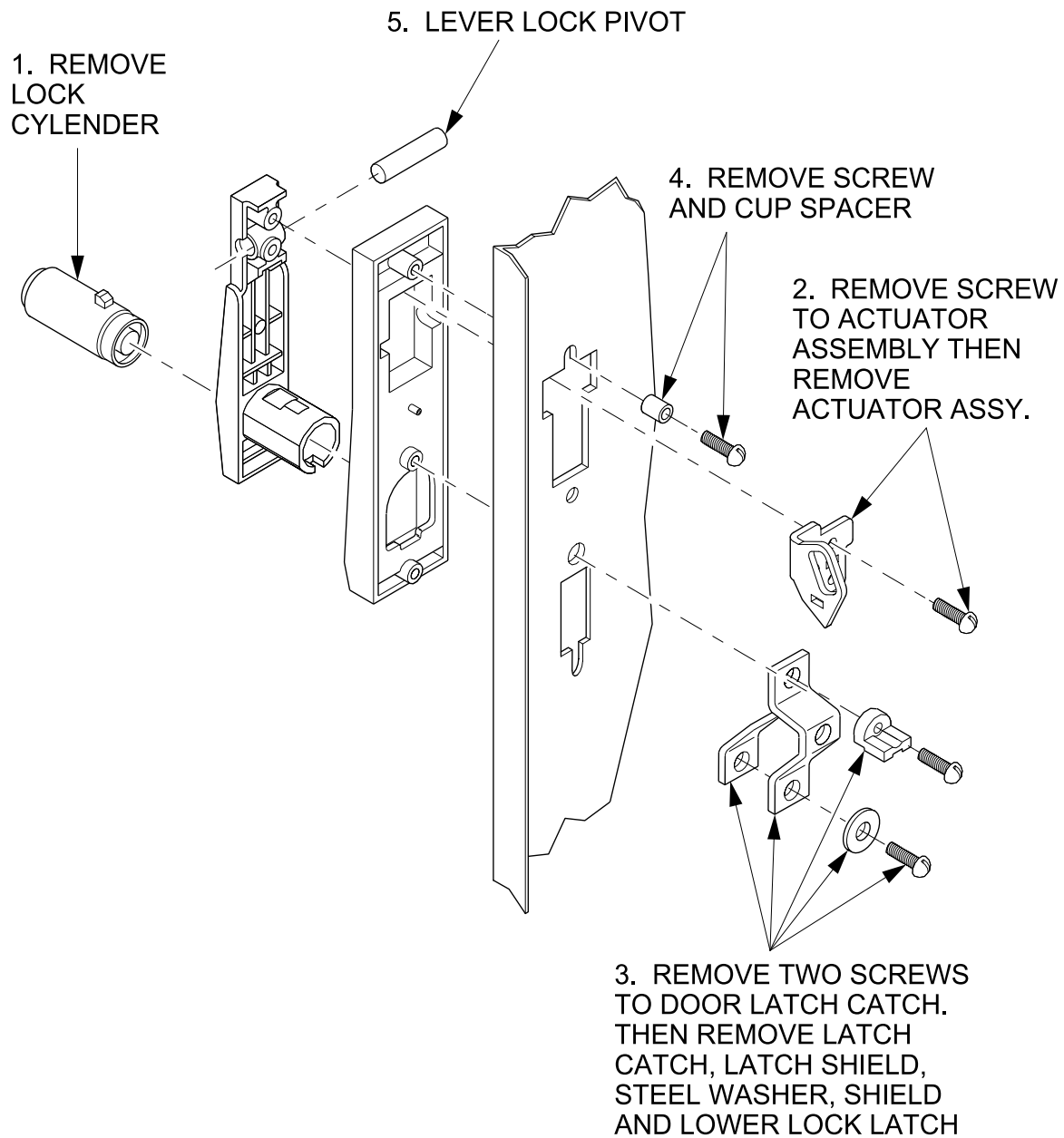

167pk042

Figure 1 Remove Old Lock and Handle Assembly

10. Install the new hi security lock lever into the base assembly.
11. Re-install the lock lever pivot.
12. Install the cylinder lock into the lock lever.
13. Install the new hi security lock lever cover. (See Figure 2)

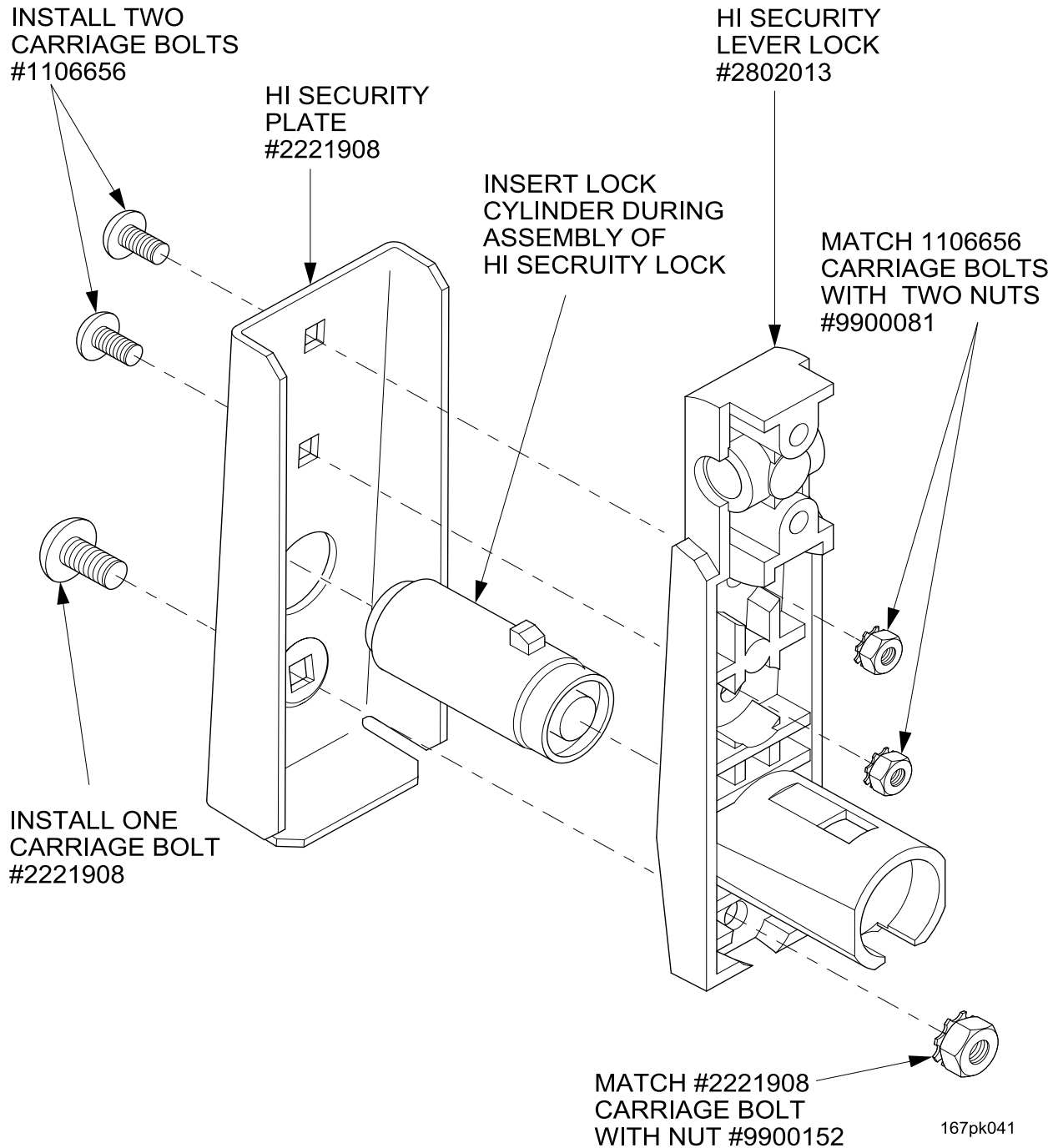

Figure 2 Install New Hi-Security Lock Assembly

-
- 14. Fasten the lock lever cover to the lock lever using the 3 carriage bolts and the 3 nuts provided in the kit. The two smaller carriage bolts are mounted to the top of the lock lever and the larger one is mounted to the bottom of the lock lever.**
 - 15. Re-install the lock assembly to the machine.**
 - 16. Re-install the screw and the cup spacer to the top of the handle assembly.**
 - 17. Re-install the door latch catch, latch shield, steel washer, and the lower lock latch.**
 - 18. Re-install the two standard screws holding the door latch catch.**
 - 19. Re-install the two standard screws holding the lock bar actuator assembly and install the lock bar actuator assembly.**

Note: You may need to reposition the lock bar in order to install the lock bar actuator.